

# ADA FLOW



**Turbidity Controller**

[www.adaflow.com.tr](http://www.adaflow.com.tr)

**Addr:** 19th floor, no:99, Buyukdere Rd, Istanbul - Turkey. **Tel:** +90 (537) 289 4118

[www.adaflow.com](http://www.adaflow.com) | [info@adaflow.com](mailto:info@adaflow.com)

# Turbidity Controller

The turbidity meter is an online monitoring instrument designed to measure the turbidity of water in municipal wastewater and industrial wastewater treatment processes. It can be used to detect turbidity changes in biochemical processes, providing continuous and accurate measurements.

## Features

- The measurement is not affected by the sample flow rate and pressure, and compensates for the influence of the environment;
- Simultaneous display of multiple parameters: measured value, output current, time, percentage of turbidity, etc.;
- 4-20mA transmission output, high and low alarm relay output control ,RS485 communication output and other variable output, system intelligent control;
- The two-point calibration method can correct the sensor error;
- A variety of installation options are available;
- A variety of measurement unit forms are available;
- Chinese and English operation interface, easy to operate.

## Key function



### ENT (menu key)

- 1.The function of entering and exiting the setting state.
- 2.This key can be used to enter the lower menu function from the upper menu.
- 3.When the parameter modification is completed, press this key to save the modified parameters and return to the previous menu. This key can complete the calibration process during the calibration operation.

### ESC (exit key)

- 1.Cancel the current operation and return to the previous menu.
2. Return to the main interface.

### UP key (Loop plus key)

- 1.This key can be used to modify the parameters at the cursor cyclically.
- 2.This key enables switching between parameter items when the cursor is over the parameter item.
- 3.Used for numeric input as an increment.
4. View calibration information.

### Right key (Loop right key)

- 1.This key allows you to select the position of the parameter and move the cursor to the parameter bit that needs to be modified.
- 2.At the end of a parameter, a parameter item can be returned.
- 3.View relay status and equipment number.

Touch the sensitivity...

# Turbidity Controller

## Technical parameter



Turbidity controller  
Measuring range: 0~4000NTU;  
Display model: LCD liquid crystal display  
Measurement unit: mg/L and NTU  
Resolution: 0.1 NTU  
Accuracy:  $\pm 5.0\%$ FS  
Repeatability:  $\pm 1.0\%$ FS  
Ambient temperature: -20~60°C  
Relative humidity: (65 $\pm$ 20)%  
Analog output: 4~20mA, Load 750 $\Omega$   
Alarm output: double relay  
Digital output: RS485  
Power supply: AC220V $\pm$ 10% or DC24V



Turbidity sensor  
Measuring range: 0...400NTU  
Temperature range: 0-60°C  
Inlet pressure: < 2bar  
Protection grade: Ip68  
Shell material: POM  
Installation: Flow through type  
Cable length: 5m (standard)  
Lowest detection point: 0.3NTU



Turbidity sensor  
Measuring range: 10...4000NTU  
Temperature range: 0-60°C  
Pressure range: 0...3bar  
Process connection: G3/4  
Protection grade: Ip68  
Shell material: 316 stainless steel  
Installation: Immersion type (avoid light)  
Cable length: 5m (standard)  
Lowest detection point: 10NTU

Touch the sensitivity...

# Turbidity Controller

## Installation and Wiring

- The meter should be installed in a place that is convenient for users and installation and maintenance personnel to read the instrument nameplate and easy to use, maintain and repair.
- To ensure safety and avoid external signals from interfering with the meter, the meter power line should be connected to the corresponding specifications, with a ground wire mark, meet the electrical standards of the socket, and the ground wire must ensure good grounding.
- The internal circuit of the meter is shown in the wiring diagram, and the voltage and power ratings are shown in the nameplate on the product.
- The power capacity of the user must meet the requirements of normal operation of the instrument.

### Controller installation precautions:

- Avoid direct sunlight and vibration of the controller.
- The controller should be installed slightly higher than the operator at eye level to facilitate the operator to browse the panel or control operations.
- Leave enough space for the opening and maintenance of the controller cabinet.

### Sensor installation precautions:

- Install the sensor in the proper location of the process to ensure representative measurements are obtained.
- Install the sensor in an accessible location to facilitate regular cleaning and maintenance of the sensor.
- The sensor should not be installed in the location where the bubbles gather to prevent the generation of interference signals.
- Install the sensor near a representative, good sampling point.
- The recommended distance between the sensor and the sampling point is no more than 1.5m (5 feet).

## Installation and Wiring

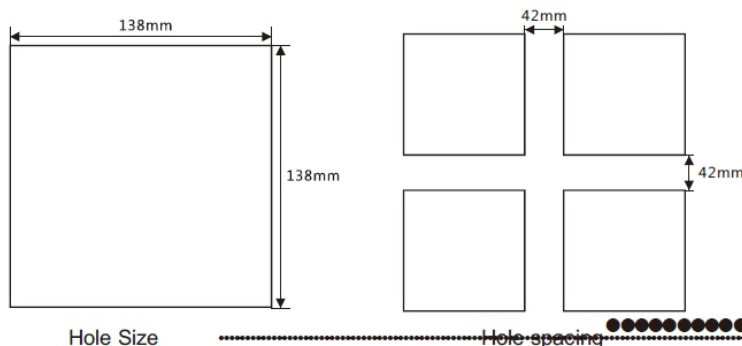

Touch the sensitivity...

## Sensor installation

### ■ Bracket immersion install (Pool Top)

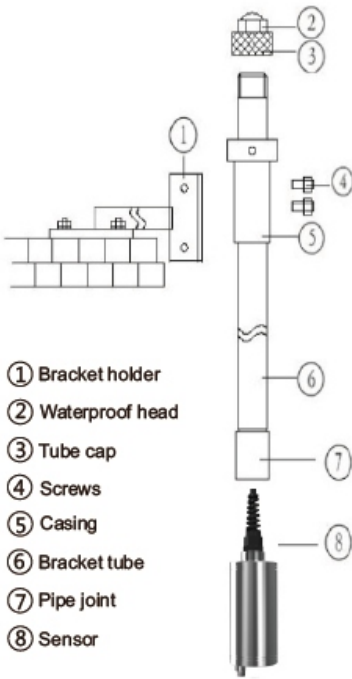

1. Fix the bracket at the appropriate position on the top of the pool.
2. According to the diagram and serial number in the left picture, install and fasten the bracket parts in turn.
3. The threads of all parts are tightened with raw tape and need to be sealed.
4. Put the installed bracket into the bracket holder and fasten it.

Note: When connecting the sensor to the mounting tube, please rotate the bracket tube instead of the sensor, otherwise the sensor cable may be damaged.

#### Pay attention to the installation:

Turbidity sensor must avoid light, otherwise it will affect the measurement.

1. Turbidity sensor should be more than 30mm away from bottom and wall in closed container.
2. If it is installed in open space, the sensor should be placed at least 1 meter under water, because light will interfere with turbidity measurement.

### ■ Flow cell install

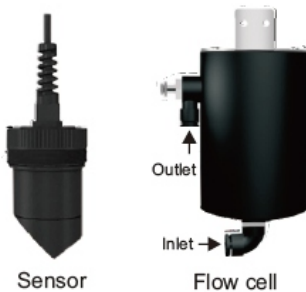

1. Prepare 2 hoses, the outer diameter is 8mm, the inner diameter is 5.5mm, one is connected to the water inlet and the other is connected to the water outlet.
2. Tighten the sensor and the thread of the flow cell to avoid water overflow.
3. The flow rate range is 15...30L/H.

Touch the sensitivity...

# Turbidity Controller

## Wiring

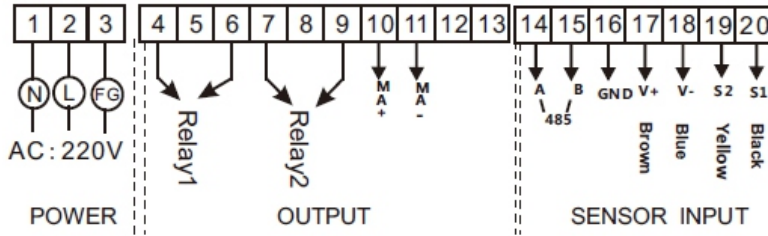

No.	Terminal	Function	Remark
1	N / DC24V+	AC / DC power input N	AC220V or 24VDC input
2	L / DC24V-	AC / DC power input L	
3	FG	AC protection ground	Ground
4	Relay1	Relay 1 NO/NC	Relay 1
5	Empty		
6	Relay1	Relay 1 common	
7	Relay2	Relay 2 NO/NC	Relay 2
8	Empty		
9	Relay 2	Relay 2 common	
10	I+	4...20mA output +	Current output
11	I-	4...20mA output -	
12	Empty		
13	Empty		
14	A	RS485 A	RS485 output
15	B	RS485 B	
16	GND		
17	V+	sensor brown wire	Sensor wiring
18	V-	sensor blue wire	
19	S2	sensor yellow wire	
20	S1	sensor black wire	

## Setting

### Measurement mode

Display interface: In measurement mode, the meter displays information such as current turbidity measurements, current time, output current, set maximum range, and percentage bar graph display.

Touch the sensitivity...

# Turbidity Controller

## Main display

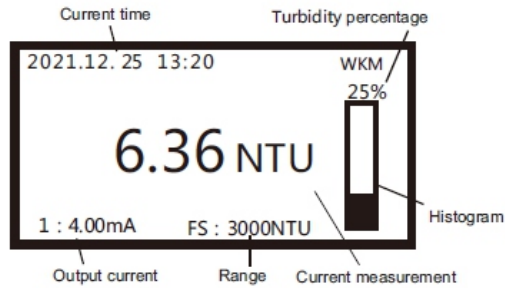

## Setting mode Introduction

Press ENT key to enter the meter menu, select the corresponding menu and press ENT key to enter the password interface, enter the parameter setting password "1001", press ENT key to enter the corresponding submenu, enter the parameter setting submenu, and pass Right key moves the cursor, the UP key set the value, the ENT key save the setting parameters.

Menu	Submenu	Range	Initial value
Calibr menu	Zero Calibr	0...MAX	0
	NTU Calibr	0...MAX	MAX
	Current1 Calib	4mA/20mA	4mA
	Current2 Calib	4mA/20mA	4mA
	Correction	0...MAX	0
Set up menu	Password Set	0000...9999	1001
	Language Set	Chinese/English	English
	Equip Set	00...99	01 115200
	Time Set	0...MAX	/
	Unit Set	mg/L, NTU	NTU
	Range Set	0...MAX	MAX
	Filtering	0-99times	0
	Elimination		0
	SampleData	00...99 Minute	00 Minute
	Relay1 Set	0...MAX	OFF
	Relay2 Set	0...MAX	OFF
	Washtime	0...MAX	OFF
	Factory Set	Cover/ Recovery	/
	Backlight Set	Open / Close / 5 Minute / 10 Minute / 1Hour	Open
Examin menu	COM Info	/	/
	Relay Info	/	/
	Equip Version	/	/
	Trend Line	/	/

Touch the sensitivity...

## Setting mode details

### 6.1 Calibration menu

#### 6.1.1 Zero Calibr

Light: 8. 1mV; Actual: 0 NTU; Samples: 6

1. Clean the sensor to remove surface dirt;
2. Immerse the sensor in the center of the distilled water container, and use a dark color container (preferably black). The bottom of the sensor should be at least 10cm away from the bottom of the bucket to avoid direct sunlight;
3. The sensor is stabilized in distilled water for 15 minutes and then enters the zero calibration menu;
4. After the voltage value is relatively stable, check the measured value, if it is not 0000.0, change it to 0000.0 through UP key and Right key, press ENT key to save. At this time, the calibrated value has been recorded by the meter, Press ESC to exit the menu.

#### 6.1.2 NTU Calibr

Light: 2170.0mV; Actual:1000 NTU; Samples:6

1. Clean the sensor to remove surface dirt;
2. Immerse the sensor in the high point standard solution or the standard solution in practical application, stabilize the sensor in the standard solution for 15 minutes, then enter the calibration interface;
3. After the voltage value is relatively stable, check the measured value, which should be the standard solution value. If not, the UP key and Right key can be used to modify the standard solution value, press ENT key to save. At this time, the calibrated value has been recorded by the meter, Press ESC to exit the menu.

#### 6.1.3 Current1 Calib

OUT: 4.00mA ; Actual: 4.01mA; Output: 10

After waiting for the output to stabilize, use UP key and Right key to modify the actual value, input the current measured current value, ENT save, ESC exit.

#### 6.1.4 Current2 Calib

OUT: 4.00mA; Actual: 4.01mA; Output: 10

Same as current 1 calibration.

Touch the sensitivity...



## Set up menu

### 6.2.1 PassWord Set

Original Pass: 1001; New Pass: 1002; Confirm: 1002

According to the menu prompt, input through the UP key and Right key, perform the corresponding steps, ENT save, ESC exit.

### 6.2.2 Language Set

1. Chinese 2. English

Use the UP key to select the language type, ENT save, ESC exit.

### 6.2.3 Equip Set

Equip NUM: 01; BaudRate: 9600

According to the menu prompt, first input the equipment number through UP and Right key, after ENT confirm, select baud rate, ENT save, ESC exit.

### 6.2.4 Time Set

DATE: 21-09-05; TIME: 15-35-12

Change the current time by UP key and Right key, press ENT to convert

### 6.2.5 Unit Set

1. NTU; 2. mg/L

Change the current option by UP key and Right key, press ENT to save the corresponding item after modification, ESC exit.

### 6.2.6 Range Set

0-4000NTU

Change the current option by UP key and Right key, press ENT to save the corresponding item after modification, ESC exit.

### 6.2.7 Filtering

01 times

Change the current option by UP key and Right key, press ENT to save the corresponding item after modification, ESC exit.

Touch the sensitivity...

# Turbidity Controller

## Set up menu

### 6.2.8 Elimination

0.05 NTU

Change the current option by UP key and Right key, press ENT to save the corresponding item after modification, ESC exit.

### 6.2.9 SamplData

00 Minute

The UP key and Right key are used to change the interval time of the data, select 00 Minute to indicate that it will not be saved. ENT save, ESC exit.

### 6.2.10 Relay1 Set

Threshold: 700. 10; ReturnV: 00. 50

The relay can be set to close/understate/overstate, which can be changed by UP key. The threshold value is the set value for alarm. When the alarm is high, the measured value is lower than the threshold value minus the return value and the alarm is cancelled. When the low alarm, the measurement value is greater than the threshold value plus the return value to cancel the alarm.

### 6.2.11 Relay2 Set

Same as relay 1 setting.

### 6.2.12 Washtime Set

1. Interval:000min; 2. Duration:0000s

Use the UP key to select the corresponding option, ENT save, ESC exit.

### 6.2.13 Factory Set

1. Load Value; 2. Over Value

Use the UP key to select the corresponding option, ENT save, ESC exit.

### 6.2.14 Backlight Set

MODE: Open

Backlight mode have: Open /Close /5 Minute /10 Minute /1Hour,

Use the UP key to select the corresponding option, ENT save, ESC exit.

Touch the sensitivity...

# Turbidity Controller

## Examin menu

### 6.3.1 COM Info

ENUM: 01; BaudRate: 9600

### 6.3.2 Relay Info

Relay1: LOW; Relay2: CHIGH; Relay3: CLOSE

### 6.3.3 EuiP version

Current Version; SN:UL2018Y19033; H040M50RV181101

### 6.3.4 Trend line

2021.12.21 12.25.00|700.52

2021.12.25 14.25.00|899.52

## Calibration

- The meter has been calibrated before leaving the factory, but due to different water quality and measuring range, to ensure the accuracy of the measurement, we recommend re-calibration before use.
- The meter has two relay outputs, which can control the dosing pump, alarm, etc. The relay setting method as follows:
  1. Power on the meter, press the MOD key, press the up and right key to select the setting menu, press ENT key enter the password 1001, press ENT to enter.
  2. Press the up and right key to select the relay 1 setting, press ENT key to enter.
  3. Press the up and right key to select high or low (above what value action or below what value action), press ENT to confirm. Input the threshold (action value), press ENT to confirm. Input the hysteresis (after returning to normal value, how many values to delay before stopping action). Press ENT to confirm and save the settings, press ESC to exit and return to the measurement interface. (The setting method of relay two is the same).

Touch the sensitivity...

# Turbidity Controller

## Calibration

- In order to ensure the accuracy of the measurement, it is recommended that the user perform calibration once a month or so. The specific steps are as follows:  
The turbidity meter is calibrated at 4 points, the standard solution needs to be calibrated in a sealed and light-proof container (black container is recommended).
- Note for selection of 4-point calibration standard solution:  
In the first step of calibration, the standard solution must be 0NTU.  
The second step of calibration, 0NTU<standard solution<30NTU.  
The third step of calibration, 30NTU< standard solution <100NTU.  
The fourth step of calibration, standard solution > 100NTU.
- The following is an example of calibration with standard solution 0, 20, 50, 200.
  1. Power on the meter, press MOD key, press the up and right key to select the calibration menu, press ENT key, enter the password 1001, press ENT to enter.
  2. The first step of calibration: Press the up and right key to select the low point calibration, put the sensor into the 0NTU standard solution, press the up and right key to input the measured value (standard solution value), observe the light intensity value, wait until the light intensity value is stable, press ENT key three times until the meter display the calibration success.
  3. The second step of calibration: press the up and right key to select the high point calibration, put the sensor into the 20NTU standard solution, press the up and right key to input the measured value (standard solution value), observe the light intensity value, wait until the light intensity value is stable, press ENT key three times until the meter display the calibration success.
  4. The third step of calibration: press the up and right key to select the low point calibration, put the sensor into the 50NTU standard solution, press the up and right key to input the actual measured value (standard solution value), observe the light intensity value, wait until the light intensity value is stable, press ENT key three times until the meter display the calibration success.
  5. The fourth step of calibration: press the up and right key to select the high point calibration, put the sensor into the 200NTU standard solution, press the up and right key to input the actual measured value (standard solution value), observe the light intensity value, wait until the light intensity value is stable, press ENT key three times until the meter display the calibration success.

Touch the sensitivity...

# Turbidity Controller

## Communication

- The MODBUS protocol only allows communication between the host (PC, PLC, etc.) and the terminal device, and does not allow data exchange between independent terminal devices, so that each terminal device does not occupy the communication line when they initialize, but only responds. Arrival signal to the machine.
- Host query: query message frame includes device address, function code, data information code, calibration code;
- Address code: indicates the address of the slave device to be selected;
- Function code: Indicates which function is to be performed by the selected slave device;
- Data segment: contains any additional information about the function to be performed by the slave device;
- Check code: used to verify the correctness of a frame of information, using CRC16 calibration rules;
- Slave response: If the slave generates a normal response, the response message has a slave address code, a function code, a data message code, and a CRC16 check code. The data information code includes data collected from the device, such as parameter measurements;
- Hardware connection: connect the signal line to the A and B terminals of the controller;
- Communication setting: The instrument specification adopts communication format of 9600, N81 (1 start bit, 8 data bits, no check, 1 stop bit), and the response speed is 0.015S;
- Communication command: function code 03 - used to read the currently displayed measurement value.

## Communication protocol

Factory default	
Address	1 (default)
Baud rate	9600 (default)
Data bit	8
Check bit	no
Stop bit	1
Function code	03

Register address	Name	Data type	Definition
0X00-0X01	Measure value	Floating point number	Floating point order ABCD
0X02-0X03	Range	Floating point number	Floating point order ABCD

Touch the sensitivity...

# Turbidity Controller

## Maintenance

### Controller maintenance

- Please check whether there is water leakage or not in the controller installation box when it is installed outdoors.
- Check the working environment of the controller. If the temperature is beyond the working stable range of the controller, please take corresponding measures. Otherwise, the controller may be damaged or its service life may be reduced.
- When cleaning the outer shell of the controller, please use a soft cloth and mild detergent, and be careful not to let moisture into the inside of the controller.
- Check whether the controller display data is normal.
- Check whether the wiring on the wiring terminal of the controller is firm. Note that the AC220V power supply should be disconnected before removing the wiring cover.

### Sensor maintenance

- The sensor needs to be cleaned regularly. It is recommended to clean the sensor once every 2-3 weeks to ensure that the front end of the sensor is clean.
- Check the cable of the sensor. The cable should not be tightened during normal operation. Otherwise, the internal wires of the cable may be broken, resulting in the sensor not working properly.
- Check whether the sensor shell is damaged by corrosion or other reasons.
- Check the connection cable plug and socket of sensor and controller for looseness.

## Maintenance

NO.	Phenomenon	Possible cause	Solution
1	LCD display is not bright	Meter or LCD power failure	Check whether the power supply is connected; Check whether the power cord of the sensor is connected inversely
2	No current output	May be current module failure or wiring failure	Please check the current output wiring is correct. Please refer to the wiring terminal diagram in the instruction
3	Controller output current does not match display current	Current output may not be properly calibrated	Please recalibrate the 4mA and 20mA outputs; Please refer to the current calibration in the menu settings.

Touch the sensitivity...